

Conical mixer dryer, reactor Type AMT

Hot/cold - pressure/vacuum reactions for dry, moist and pasty goods.

The mixer dryer, reactor is suitable for powders, suspensions, pastes and dough (testing is recommended). The drying process is carried out extremely carefully. Complete discharge is possible if goods are flowable. The dryer/reactor can be designed to conform with FDA-standards, to be used as a sterile reactor. In this case, it also meets EHEDG requirements and the 3-A Sanitary Standards.

Gear box equipped with a cooling device

The reactor is vacuum and pressure tight and heatable by steam, thermal oil or water. On request also insulated.

SinConvex® mixing tool: fully temperature controlled on demand, excellent mixing quality, high degree of discharging

Choppers can improve the drying process by deagglomeration (mechanically sealed).

Mixing chamber: ATEX Zone 20

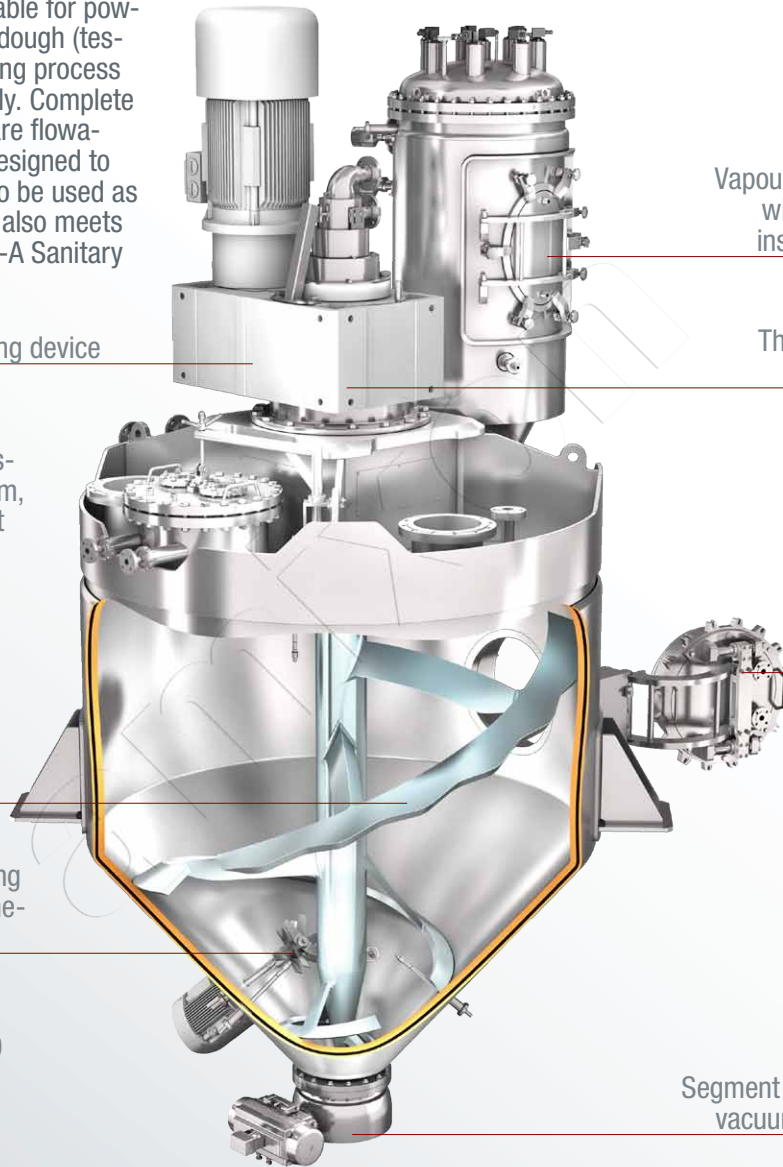

Vapour filter heatable, equipped with Clever-Cut®-designed inspection door on demand

The mixing tool is mounted and driven only on top.

Manhole heatable, can be located on the top or on the side.

Mixing chamber and mixing tool are fully welded and polished.

Segment ball valve without cavity, vacuum and pressure resistant



Headplate lifts automatically

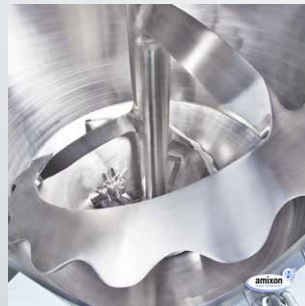

Mixing tool heated



Vapor filter on the headplate

AMT-1-7111-2020 EN



LIFESCIENCE



FOOD



ANIMAL CARE



DETERGENTS



CERAMICS



POLY

User Benefits

- ✓ Particularly fast and gentle drying at low temperatures and low rotational frequencies if, for example, fungal spores, bacterial cultures or effect pigments should be dried.
- ✓ It is also possible to mix intensively deagglomerating in the same apparatus, at higher peripheral speeds and with several HighShearBlades.
- ✓ The mixer is optionally accessible from the side or from above, it can be cleaned fast, safely and convenient; manually or automatically. On request, it can also be sterilized with steam.
- ✓ The mixing tool is fully heated. It is mounted and driven only from above.
- ✓ The apparatus is highly gastight. A vacuum of 1 mbar abs. is possible.
- ✓ Particularly large heat exchange surfaces advantage extremely short drying times.

Piloting

amixon® places special importance on the pilot phase in the test centre. Your mixing processes are simulated here. This way, we support you in your product development phase. amixon® has a main test center in Paderborn (Germany). Further test centers are situated in Japan, Thailand, India and the USA.



Technical Data

Conical mixer dryer, reactor Type AMT Type designation is equal to the batch size in liters. Ideal mixing and drying takes place even at lower filling levels.	Approximate gross volume of the mixer	Approximate dimensions of the standard version. Please ask for detailed dimension sheets!						The rotational frequency can vary widely from about 0,8 m/s to about 3,5 m/s. Usually amixon® mixers dryers, reactors operate at low speed. about		The drive power required can vary widely depending on the bulk density, flow characteristics (viscoplastic phases), rotational frequency and the processing task (such as deagglomeration).		Weight may vary considerably depending on the pressure level, size of the drive and the type of design. The additional dynamic loads are very low.
		A	B	C	D	E	F	from	to	from	to	
		Liter = dm ³	Liter	mm	mm	mm	mm	mm	mm	Rotation per minute	kW	
100	130	396	735	200	660	1166	478	28	105	1	3	980
200	260	473	935	200	825	1431	590	22	83	3	7	1230
300	390	462	1142	200	825	1431	553	19	73	4	12	1350
400	520	451	1142	200	968	1643	689	17	66	6	16	1500
500	650	462	1135	200	1100	1670	681	16	61	7	20	1956
600	780	473	1325	200	1100	1696	779	15	57	8	23	2300
800	1040	451	1395	220	1298	1982	741	14	52	9	29	2780
1000	1300	583	1595	220	1298	2014	914	13	48	11	35	3160
1500	1950	825	1805	220	1485	2332	1042	11	42	14	46	5060
2000	2600	858	1975	220	1639	2385	1147	10	38	16	56	5699
2500	3250	869	2085	220	1881	2862	1177	10	35	19	64	6320
3000	3890	880	2325	220	1881	2809	1312	9	33	21	72	7410
4000	5180	891	2455	220	2057	2544	1433	8	30	24	85	9496
5000	6470	891	2395	230	2211	2756	1538	8	28	28	97	12920
6000	7760	891	2685	230	2365	2809	1643	7	26	31	108	14200
7000	9040	968	2875	230	2640	3074	1568	7	25	33	118	15900
8000	10330	1045	3103	230	2640	3392	1808	6	24	36	128	18000
9000	11610	1045	3245	240	3080	3816	1530	6	23	38	136	19400
10000	12890	1045	3215	240	3080	4049	1680	6	22	41	145	21600
12000	15460	1100	3515	240	3080	4049	1905	6	21	45	160	25900
15000	19300	1210	3835	240	3080	4049	2356	5	19	51	181	31050

- Bigger machines up to 50 m³ are available on demand! If desired, amixon® can modify the proportions: "low profile" if the height is limited or "slim profile" if the available ground area is limited! On demand the machine is manufactured according to the European pressure rule or the American ASME-rule. On demand amixon® can also manufacture the vapour filter (vacuum pumps and condensers can be purchased by the customer, as they are not part of amixon®'s range of manufacturing).
- As a welding specialist, amixon® is qualified by European, Japanese and American authorities with regard to different materials. The materials in contact with the mixing goods are either mild steel S355J2Ge, Hardox, austenitic stainless steels 1.4301, 1.4541, 1.4571, 1.4404, 1.4539, 1.4529, Duplex stainless steels 1.4462, 1.4162, 1.4363 and Alloy 59-2.4605, Hastelloy C22 and nickel.
- The mixers meet the highest hygienic requirements and comply with the EHEDG guidelines for dry and wet cleaning. They also meet the FDA hygiene guidelines and the design requirements of 3-A Sanitary Standards.

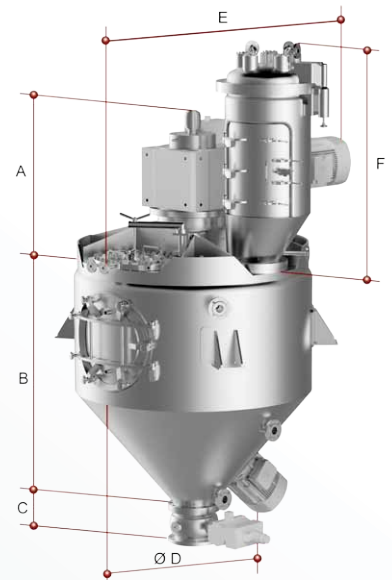

amixon GmbH
Halberstädter Straße 55
33106 Paderborn
Germany

Tel. +49 (0) 52 51 / 68 88 88-0
Fax +49 (0) 52 51 / 68 88 88-999
E-Mail sales@amixon.com
www.amixon.com



amixon® manufactures high precision mixers, vacuum mix-dryers, synthesis reactors and granulators with maximum fabrication depth. All components of the amixon®-mixers are made in Germany. The production of the machines takes place exclusively in the amixon®-factory in Paderborn, Germany.

© by amixon GmbH, Paderborn. Reprinting or transfer to electronic media only permitted after written approval. We reserve the right to make changes due to progress in process engineering and manufacturing technology.