

# Conical mixer Type AM

patented

The ideal mixing quality for dry, moist and viscous materials at variable filling levels in a fast mixing process

Guarantees ideal mixing results for dry powder, wet suspensions, as well as liquids, paste and dough. The vertical mixer can be designed to conform with FDA and 3-A Sanitary Standards to be used as a sterile mixer and reactor which also meets EHEDG requirements.

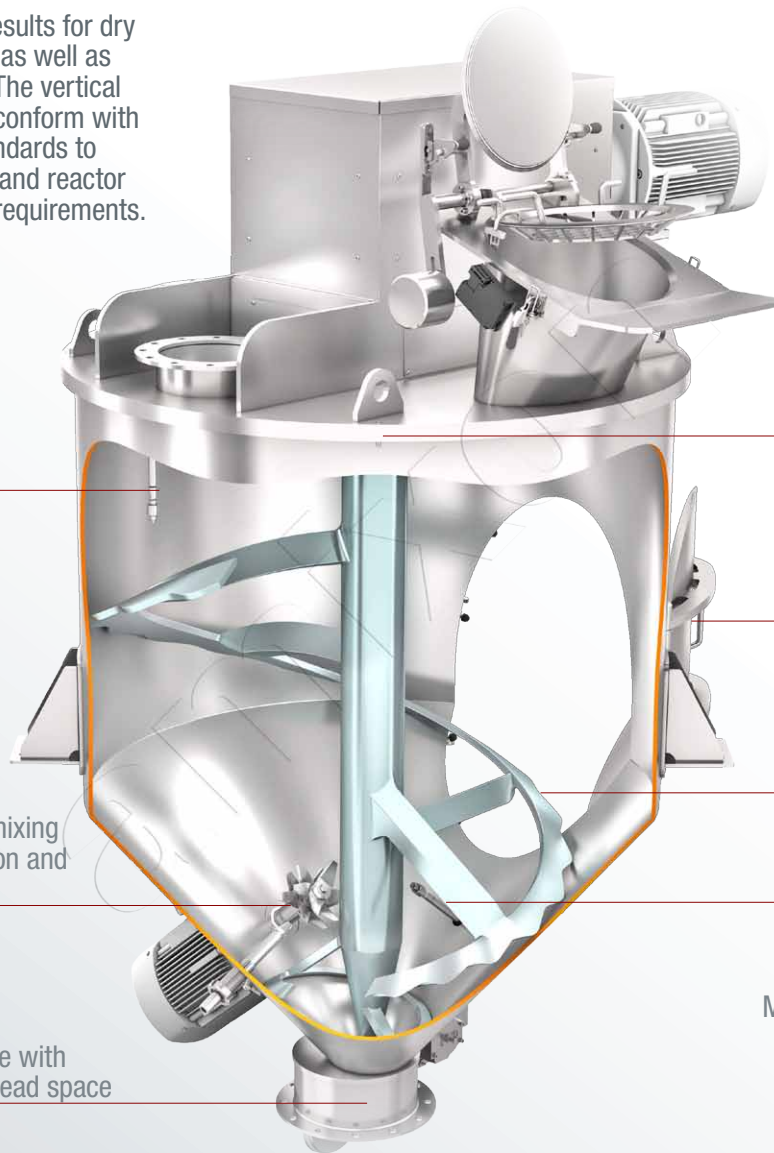

Washing nozzle

Mixing chamber and mixing tool welded and polished without gaps

Choppers to improve the mixing process by deagglomeration and liquid distribution

Standard connection flange with outlet flap, seals without dead space

Mixing tool driven and supported only from above

Large inspection door without dead space designed by Clever-Cut®

SinConvex® helical mixing tool, patented; excellent mixing quality, high degree of discharging

Liquid addition by means of atomizing nozzle on demand

Mixing chamber: ATEX Zone 20



Model AM 2000 for Instant food

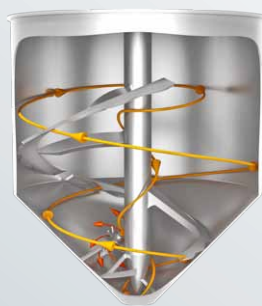

Total homogenization by three-dimensional rearrangement

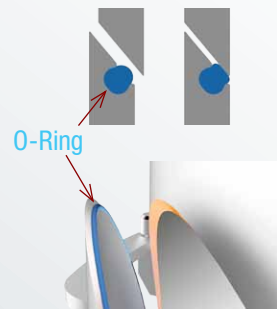

Hygienic inspection door without dead space, designed by Clever-Cut®

AM-1-7003-2020 EN



LIFESCIENCE



FOOD



ANIMAL CARE



DETERGENTS

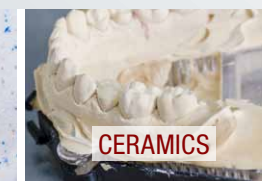

CERAMICS



POLY

## User Benefits

- ✓ This precision mixer is universally applicable.
- ✓ Provides ideal mixing qualities in a very short mixing time.
- ✓ The filling levels can vary from approx. 5% to 100%.
- ✓ Free-flowing goods discharge up to 99.98% and better.
- ✓ Mixing tool driven and supported only from above. Everything is fully welded and polished without gaps.
- ✓ The inspection door is especially hygienic - manufactured according to the Clever-Cut® process with OmegaSeal® and seals permanently free of dead space. On request also vacuum-tight or against overpressure.

## Piloting

amixon® places special importance on the pilot phase in the test centre. Your mixing processes are simulated here. This way, we support you in your product development phase. amixon® has a main test center in Paderborn (Germany). Further test centers are situated in Japan, Thailand, India and the USA.



## Technical Data

Conical mixer <b>Type AM</b> The type designation is equal to the batch size in liters. Ideal mixing even at low filling levels. Intermediate sizes are available in 100 liter steps.	Approximate gross volume of the mixer	Approximate dimensions of the standard version. Please ask for detailed dimension sheets!					The rotational frequency can vary widely from about 0,8 m/s to about 3,5 m/s. Usually amixon® conical mixers operate at low speed.  about		The drive power required can vary widely depending on the bulk density, flow characteristics, rotational frequency and the processing task (such as deagglomeration).		Weight may vary considerably depending on the size of the drive and the type of design. The additional dynamic loads are very low.
		A	B	C	D	E	from	to	from	to	
		Liter = dm³	Liter	mm	mm	mm	mm	mm	Rotation per Minute	kW	
100	130	360	712	157	620	1100	28	105	1	3	730
200	260	430	912	157	770	1350	22	83	3	7	890
300	390	420	1119	157	770	1350	19	73	4	12	890
400	520	410	1119	157	900	1550	17	66	6	16	1040
500	650	420	1112	157	1020	1575	16	61	7	20	1350
600	780	430	1305	157	1020	1600	15	57	8	23	1560
800	1040	410	1375	157	1200	1870	14	52	9	29	1870
1000	1300	530	1575	157	1200	1900	13	48	11	35	2080
1500	1950	750	1785	157	1370	2200	11	42	14	46	3330
2000	2600	780	1960	157	1510	2250	10	38	16	56	3600
2500	3250	790	2070	165	1730	2700	10	35	19	64	3850
3000	3890	800	2310	157	1730	2650	9	33	21	72	4370
4000	5180	810	2440	157	1890	2400	8	30	24	85	5540
5000	6470	810	2380	157	2030	2600	8	28	28	97	7590
6000	7760	810	2670	157	2170	2650	7	26	31	108	8130
7000	9040	880	2860	157	2424	2900	7	25	33	118	8840
8000	10330	950	3088	157	2424	3200	6	24	36	128	9880
9000	11610	950	3230	157	2824	3600	6	23	38	136	10400
10000	12890	950	3200	157	2824	3820	6	22	41	145	11440
12000	15460	1000	3500	157	2824	3820	6	21	45	160	13520
15000	19300	1100	3825	157	2824	3820	5	19	51	181	15600

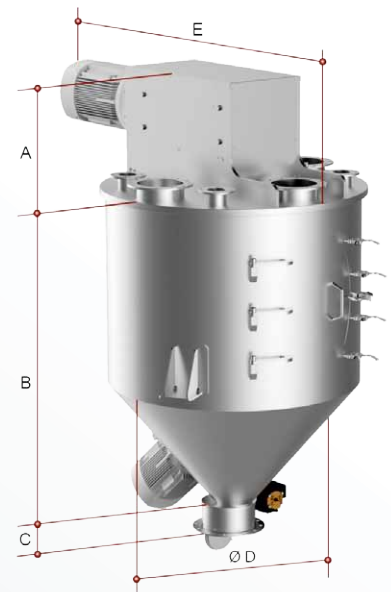

- Bigger mixers up to 50 m³ are available on demand! Usually the vessel dimensions are relatively cubic. If desired, amixon® can modify the proportions: "low profile" if the height is limited or "slim profile" if the available ground area is limited.
- As a welding specialist, amixon® is qualified by European, Japanese and American authorities with regard to different materials. The materials in contact with the mixing goods are either mild steel S355J2Ge, Hardox, austenitic stainless steels 1.4301, 1.4541, 1.4571, 1.4404, 1.4539, 1.4529, Duplex stainless steels 1.4462, 1.4162, 1.4363 and Alloy 59-2.4605, Hastelloy C22 and nickel.
- The mixers meet the highest hygienic requirements and comply with the EHEDG guidelines for dry and wet cleaning regime. They also meet the FDA hygiene guidelines and the design requirements of 3-A Sanitary Standards.



amixon GmbH  
Halberstädter Straße 55  
33106 Paderborn  
Germany

Tel. +49 (0) 52 51 / 68 88 88-0  
Fax +49 (0) 52 51 / 68 88 88-999  
E-Mail sales@amixon.com  
www.amixon.com



amixon® manufactures high precision mixers, vacuum mix-dryers, synthesis reactors and granulators with maximum fabrication depth. All components of the amixon®-mixers are made in Germany. The production of the machines takes place exclusively in the amixon®-factory in Paderborn, Germany.

© by amixon GmbH, Paderborn. Reprinting or transfer to electronic media only permitted after written approval. We reserve the right to make changes due to progress in process engineering and manufacturing technology.